

HCV

series



UL Swing Check Valve – Grooved Ends

- Size: 2"(DN50) to 12"(DN300)
- Working Pressure: 350 PSI
- Test Pressure: 700 PSI
- Working Temp.: 0°C to 80°C (32°F to 176°F)
- Valve Standard: UL312
- Connection Standard: ANSI/AWWA C606
- Test Standard: UL312



HCV-350GG

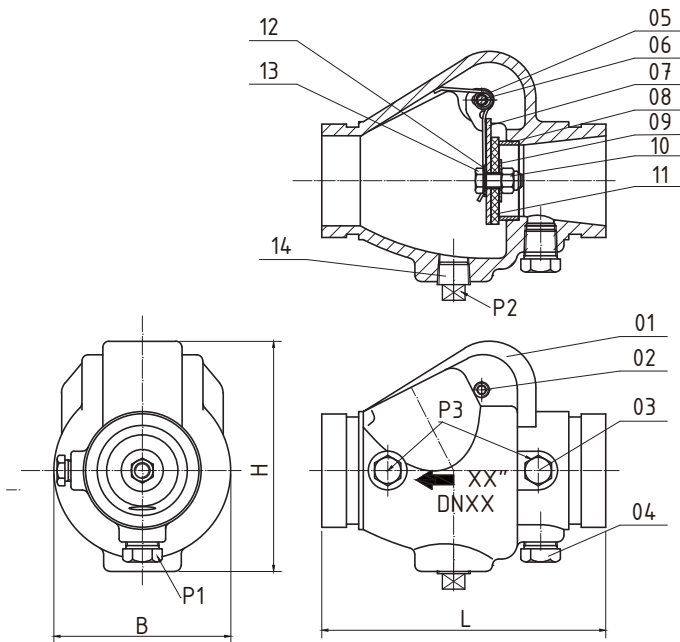

ITEM	PARTS	MATERIAL
1	VALVE BODY	A536 65-45-12
2	BOLT	STEEL
3	PLUG	STEEL
4	PLUG	STEEL
5	SPRING	304
6	HINGE PIN	304
7	CLAPPER	304
8	SEAT	C95400
9	CLAMPING RING	304
10	LOCKNUT	304
11	FACING SEAL	EPDM
12	GASKET	EPDM
13	BOLT	304
14	PLUG	STEEL

SIZES		DIMENSIONS (MM)												
Inch	mm	B	H	L	P1			P2				P3		
2"	DN 50	100	131	169	1/2-14NPT	1/2-14NPT	3/4-14NPT	1-11.5NPT	1 1/4-11.5NPT	1 1/2-11.5NPT	2-11.5NPT	1/4-18NPT	3/8-18NPT	1/2-14NPT
2.5"	DN 65	104	141	181	1/2-14NPT	1/2-14NPT	3/4-14NPT	1-11.5NPT	1 1/4-11.5NPT	1 1/2-11.5NPT	2-11.5NPT	1/4-18NPT	3/8-18NPT	1/2-14NPT
3"	DN 80	128	166	198	1/2-14NPT	1/2-14NPT	3/4-14NPT	1-11.5NPT	1 1/4-11.5NPT	1 1/2-11.5NPT	2-11.5NPT	1/4-18NPT	3/8-18NPT	1/2-14NPT
4"	DN 100	151	195	214	1/2-14NPT	1/2-14NPT	3/4-14NPT	1-11.5NPT	1 1/4-11.5NPT	1 1/2-11.5NPT	2-11.5NPT	1/4-18NPT	3/8-18NPT	1/2-14NPT
5"	DN 125	189	223	248	1/2-14NPT	1/2-14NPT	3/4-14NPT	1-11.5NPT	1 1/4-11.5NPT	1 1/2-11.5NPT	2-11.5NPT	1/4-18NPT	3/8-18NPT	1/2-14NPT
6"	DN 150	220	252	270	1/2-14NPT	1/2-14NPT	3/4-14NPT	1-11.5NPT	1 1/4-11.5NPT	1 1/2-11.5NPT	2-11.5NPT	1/4-18NPT	3/8-18NPT	1/2-14NPT
8"	DN 200	279	303	325	1/2-14NPT	1/2-14NPT	3/4-14NPT	1-11.5NPT	1 1/4-11.5NPT	1 1/2-11.5NPT	2-11.5NPT	1/4-18NPT	3/8-18NPT	1/2-14NPT